

THE
PINNACLE
OF
ENGINEERING
+ DESIGN

BUGATTI | *FACTOR*

A RADICAL FUSION OF HYPERCAR ENGINEERING AND ELITE CYCLING PERFORMANCE.



BORN FROM A SHARED PHILOSOPHY OF OBSESSIVE ATTENTION TO DETAIL AND PERFORMANCE WITHOUT LIMITS, THE BUGATTI FACTOR ONE REPRESENTS A NEW BENCHMARK IN PIONEERING CYCLING DESIGN. EVERY ELEMENT OF THE BIKE HAS BEEN METICULOUSLY ENGINEERED TO DELIVER UNCOMPROMISING AERODYNAMIC EFFICIENCY AND RIDE QUALITY, DRAWING DIRECTLY FROM BUGATTI'S LEGACY OF ENGINEERING EXCELLENCE AND FACTOR'S PROVEN EXPERTISE IN ELITE-LEVEL BICYCLE DESIGN.



BUGATTI | *FACTOR*

FACTOR IS A PERFORMANCE ENGINEERING BRAND DEDICATED TO ONE THING: BUILDING THE FASTEST BIKES POSSIBLE THROUGH VALIDATED DESIGN. USING CFD, WIND-TUNNEL DEVELOPMENT, RACE TESTING, IN-HOUSE ENGINEERING AND MANUFACTURING, FACTOR CREATES A COMPLETE SYSTEM, DESIGNED TO DELIVER REAL GAINS AT REAL SPEEDS. BUGATTI FACTOR ONE BEGINS WHERE THE RULES END, TO CREATE THE FASTEST ROAD BIKE IN THE WORLD.



PRODUCT OVERVIEW

1. THE PLATFORM: BUGATTI FACTOR ONE
2. THE ILLEGAL ADVANTAGE: WIDE STANCE FORK = REDUCED DRAG
3. THE WHEELS: BLACK INC HYPER 62 + BESPOKE COMPONENTS



BUGATTI | *FACTOR*

BEYOND THE RULEBOOK

THE FACTOR ONE BEGAN WITH A CHANGE IN WHAT WAS ALLOWED, AND AN AMBITION TO REACH THE EDGE OF LEGALITY WITH REAL, PROVABLE SPEED. IT EVOLVED FROM YEARS OF AERO LEARNINGS ACROSS HANZŌ TRACK AND OSTRO VAM, BUILT AND VALIDATED THROUGH CFD, WIND TUNNEL WORK, AND RACING REALITY. THE FACTOR ONE IS PROVEN THE WORLD'S FASTEST UCI-LEGAL ROAD BIKE. BUGATTI FACTOR ONE STARTS FROM THAT TRUTH, THEN REMOVES THE FINAL CONSTRAINT IMPOSED BY THE UCI, CYCLING'S GOVERNING BODY



AERODYNAMICS

FACTOR'S DEFINING BREAKTHROUGH IS FRONT-END AIRFLOW MANAGEMENT, DESIGNED TO CONTROL TYRE SPILL AND SUSTAIN AERO ADVANTAGE THROUGH REAL-WORLD YAW. BUGATTI FACTOR ONE APPLIES THE SAME SYSTEM LOGIC WITH A WIDER FORK STANCE IN A NON-UCI CONFIGURATION, PURSUING LOWER DRAG AND HIGH-SPEED STABILITY WITHOUT COMPROMISE.

FULLY INTERNAL
ROUTING (FACTOR ONE CORE)

INTEGRATED COCKPIT
SYSTEM (FACTOR ONE CORE)



CHIN / FORWARD FAIRING
AIRFLOW MANAGEMENT
(FACTOR ONE CORE)

WIDE-STANCE
FORK ARCHITECTURE
(BUGATTI-ONLY)



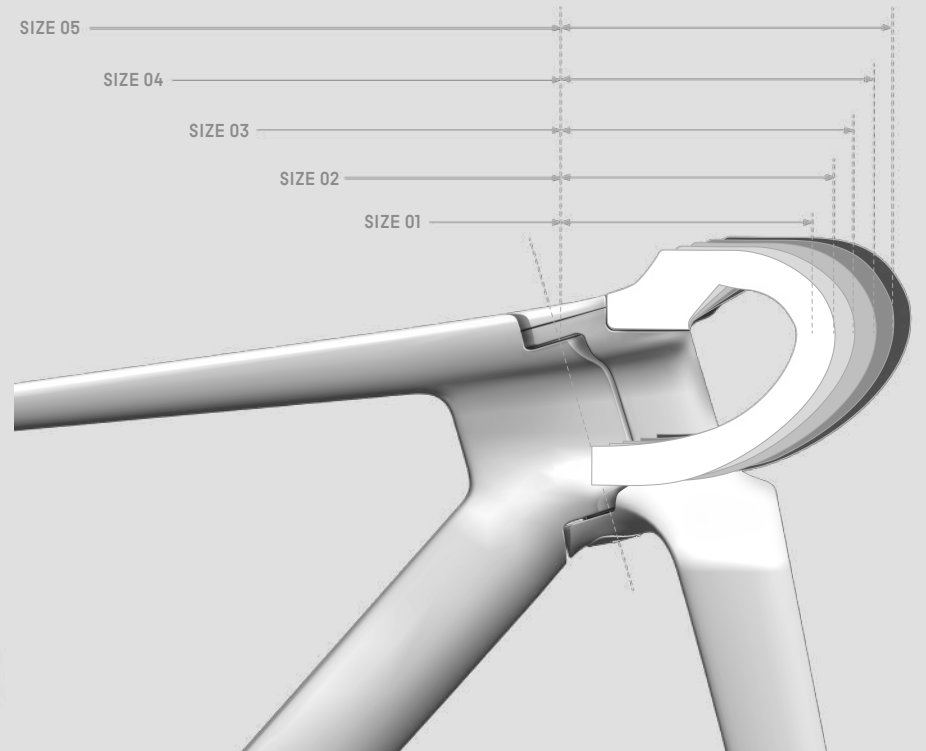
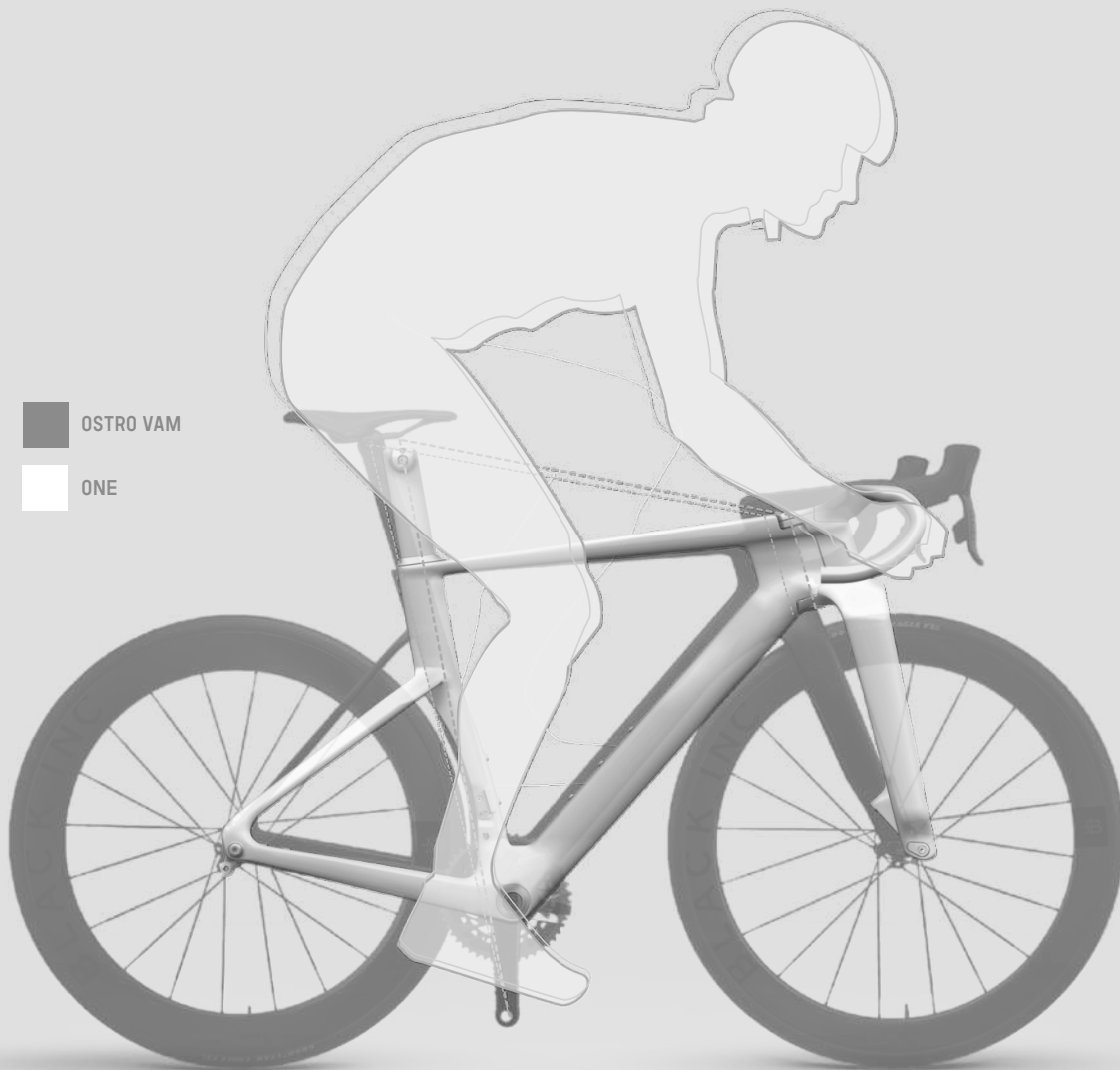

THE ONE PLATFORM IS ENGINEERED AROUND THE MODERN RACER'S POSITION, FORWARD SADDLE, SHORTER CRANKS, NARROWER BARS, WHILE ENHANCING BALANCE, STABILITY, AND CONFIDENCE AT SPEED.

COCKPIT SIZING IS BUILT INTO THE INTEGRATED BAR SYSTEM, ENABLING AGGRESSIVE REACH WITHOUT THE INSTABILITY OF EXTREME STEMS.

COCKPIT SIZES 1—5 (110—150MM EQUIVALENTS)

ADJUSTABLE SEATPOST HEAD: VSTA 73.5°—77°

INCREASED BB DROP (STABILITY WITH MODERN FIT TRENDS)

RIDER INTEGRATION



BUGATTI CONFIGURATION

A BUILD CONCEIVED AS A WHOLE SYSTEM.

Frame: To match Bugatti's carbon fibre weave, the outer-most carbon layer uses a special 3K twill weave that reflects the same effort and attention to detail lavished on Bugatti automobiles.

Wheels: Black Inc Hyper 62, 1298 grams a pair, advanced carbon layup tuned to maximise torsional stiffness, co-moulded boomerang spokes ensure fibre continuity, decreasing mass and opening a new world of aerodynamic opportunities.

Powermeter / Cranks: Made in Germany, SRM ORIGIN PM9 powermeter with THM Crank arm, fitted with CARBON-Ti chainring with 3K glossy structural carbon fiber with Titanium Grade 5 teeth, branded Bugatti.

Brake Rotors: Made in Italy by CARBON-TI, the disc brake rotors use a carbon central body and a steel braking track for greater braking power, modularity, and heat dissipation in a lightweight package, branded Bugatti.

Saddle: Custom Selle Italia Carbon shelled saddles are wrapped in the same Alcantara material used on Bugatti steering wheels, offering an elegant appearance and supple ride.

Tyres: Bugatti Continental Grand Prix 5000 TT tyres specially branded and with the French Racing Blue sidewall, these high-performance tyres offer exceptionally low rolling resistance combined with a low weight.

Ceramicspeed: Made in Denmark, the world's lowest-friction bearings. Fitted in bottom bracket, wheels, and their award-winning OSPW system to fully optimise the drivetrain.

BUGATTI CUES, INTERPRETED THROUGH SPEED.



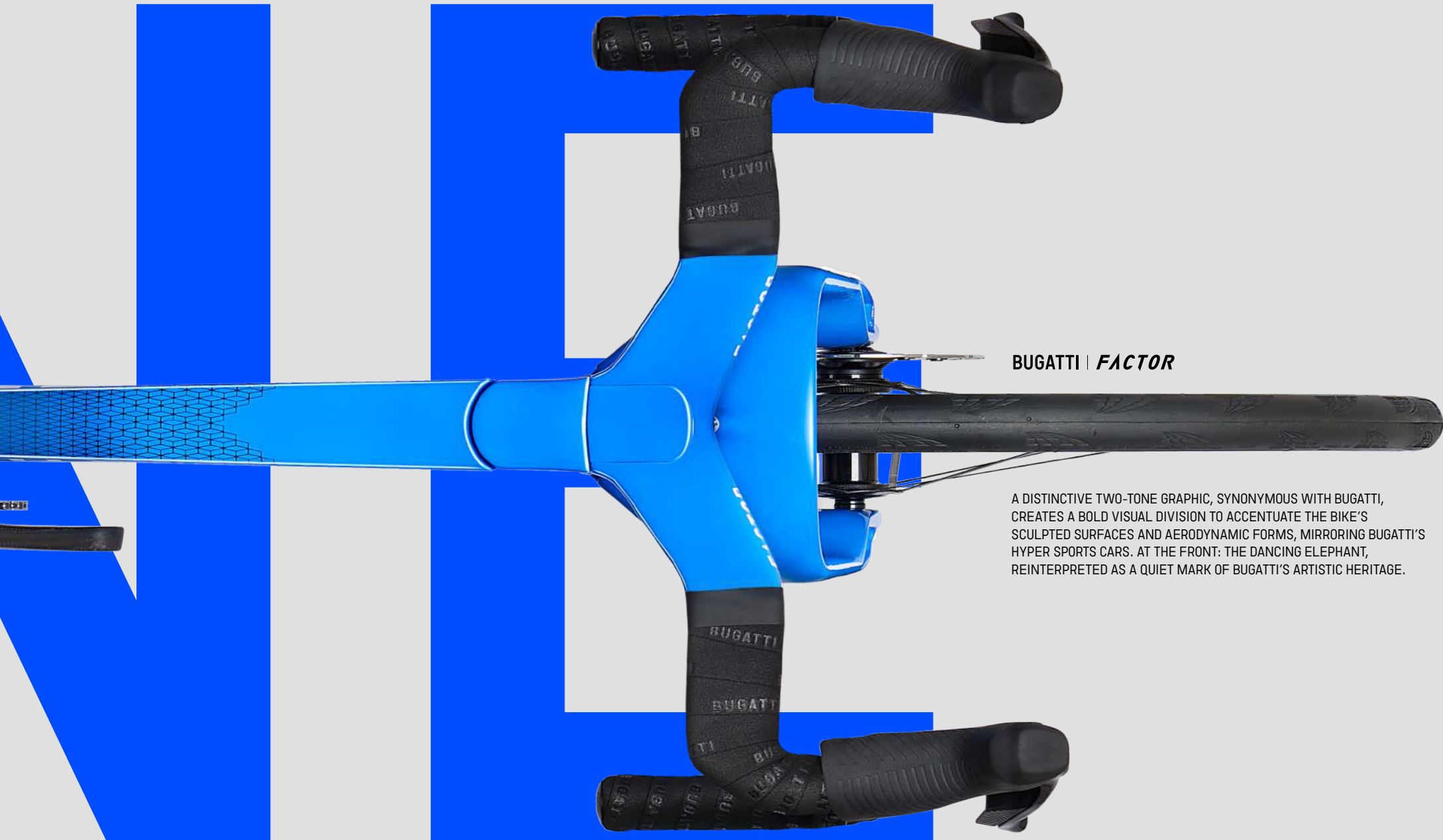

BUGATTI | *FACTOR*

A DISTINCTIVE TWO-TONE GRAPHIC, SYNONYMOUS WITH BUGATTI, CREATES A BOLD VISUAL DIVISION TO ACCENTUATE THE BIKE'S SCULPTED SURFACES AND AERODYNAMIC FORMS, MIRRORING BUGATTI'S HYPER SPORTS CARS. AT THE FRONT: THE DANCING ELEPHANT, REINTERPRETED AS A QUIET MARK OF BUGATTI'S ARTISTIC HERITAGE.

BUGATTI | *FACTOR*

250

UNITS. INDIVIDUALLY NUMBERED.

PRODUCED IN STRICTLY CONTROLLED QUANTITY.

BUILT FOR COLLECTORS, ENTHUSIASTS, AND ATHLETES SEEKING THE RAREST EXPRESSION OF PERFORMANCE CYCLING, WHERE ENGINEERING PRECISION AND DESIGN INTENT ARE INSEPARABLE.

BUGATTI | *FACTOR*

ONE

SPEC



FRAME	TEXTREME®, TORAY®, NIPPON GRAPHITE® PITCH-BASED FIBER, 3K FINISH
FORK	BUGATTI WIDE FRONT END 147 MM WIDTH (VS 115 MM UCI LIMIT) 0 AND 30MM SETBACK AVAILABLE
SEATPOST	FACTOR INTEGRATED BARSTEM REACH 80MM, DROP 120MM. 380 BARWIDTH, 5 REACH OPTIONS
BARSTEM	FSA 1-1/8" UPPER AND LOWER BEARINGS
HEADSET	CERAMICSPEED T47 ALPHA
BOTTOM BRACKET	INTERNAL CABLE ROUTING
CABLE ROUTING	DISC BRAKE 160MM FRONT & REAR
BRAKE	CHAIN RING 48/35
MAX CHAINRING 54-TOOTH	BLACK INC HYPER 62 CO-MOULDED HUB FLANGES + BONDED SPOKES, HIDDEN NIPPLES, ULTRA-LOW SYSTEM
WHEELS	BUGATTI-BRANDED CONTINENTAL TT TYRES
TYRES	SRAM RED
DRIVETRAIN	SRM ORIGIN PM9
CRANK	BUGATTI-BRANDED CARBON-TI, X-CARBORING 48/35
CHAIN RING	BUGATTI-BRANDED CARBON-TI X-FIX ROAD BLACK BUGATTI
ROTORS	CERAMICSPEED OSPW
OSPW	BUGATTI-BRANDED SELLE ITALIA SLR CARBON
SADDLE	BUGATTI ENGRAVING: NUMBERED PLATE 1 OF 250
BATCH	FACTOR / POST CARRYCO. LOOMER TRAVEL BAG
BIKE BAG	CUSTOM BUGATTI BARTAPE
BARTAPE	BLACK INC AERO INTEGRATED BOTTLE CAGES & 3D CUSTOM COMPUTER MOUNT
INCLUDED ACCESSORIES	LIMITED LIFETIME WARRANTY
WARRANTY	

BUGATTI | *FACTOR*

ONE

GEOMETRY

SIZE	STACK mm	REACH mm	STA[°]	HTA[°]	BB DROP mm	TRAIL mm	FORK OFFSET mm	CHAINSTAY mm	WHEELBASE mm
47	503	390	76.5	72.5	77	57.4	48	405	972
52	523	396	76.0	73.3	77	57.5	43	405	972
54	542	404	76.0	73.3	75	57.5	43	405	988
56	565	412	75.5	73.3	75	57.5	43	405	1002
58	587	421	75.5	73.3	75	57.5	43	410	1020

STA RANGE VIA SEATPOST ADJUSTABILITY: 73.5°—77°.

EFFECTIVE FIT MATCHES OSTRO VAM DESPITE STEEPER NOMINAL STA.

IDENTICAL STEERING GEOMETRY ACROSS SIZES; TOE OVERLAP ELIMINATED IN SMALL FRAMES.

BUGATTI | *FACTOR*

FACTOR

BORN FROM AN UNCOMPROMISING PURSUIT OF SPEED, FACTOR EXISTS TO BUILD THE MOST ADVANCED PERFORMANCE BICYCLES IN THE WORLD. WE FUSE AERODYNAMIC SCIENCE, ADVANCED COMPOSITES, AND PRECISION INTEGRATION TO CREATE COMPLETE RACE SYSTEMS, WHERE EVERY SURFACE, INTERFACE, AND GRAM EXISTS FOR A REASON. OUR WORK IS DEFINED BY RIGOR AND RESTRAINT: NO DECORATION WITHOUT FUNCTION,

NO PERFORMANCE CLAIM WITHOUT PROOF. FACTOR DELIVERS THE CONFIDENCE OF SPEED YOU CAN FEEL AND PERFORMANCE YOU CAN MEASURE, PRIDE IN WHAT YOU OWN, AND CERTAINTY IN WHAT IT CAN DO. EACH CREATION REFLECTS THE SAME BELIEF: ENGINEERING TRUTH, MADE VISIBLE. ENGINEERED AS A SYSTEM. CRAFTED TO THE HIGHEST STANDARD. **Never. Status. Quo.**™



NEVER. STATUS. QUO.

CONTACT _ DAVID MILLAR
CHIEF BRAND OFFICER
FACTOR BIKES _ GIRONA
MOBILE: +34677655954
EMAIL: DAVID@FACTORBIKES.COM

FACTORBIKES.COM

FACTOR

