

CANYON



THE PURSUIT OF SPEED: SPEEDMAX CFR TRACK

CANYON UNVEIL TRACK BIKE DEBUT, SPEEDMAX CFR TRACK

Koblenz, Germany, embargo until 3 August 2023, 11:00 CEST

After two years of intensive development, with 442 super-computer runs, 312 wind tunnel analyses, and 155 hours of track testing with the world's finest track cyclists, Canyon are proud to announce the Speedmax CFR Track. The result of an unparalleled collaboration between world-class engineers and the fastest professionals in the sport, and the fastest bike the German marque has ever produced.

Canyon's fastest ever bike

When every second counts, every watt counts. And when every watt counts, the world's best athletes rely on the Canyon Speedmax. Renowned for its triumphant success in triathlons, claiming five Triathlon World Championship titles, the Speedmax has solidified its place as one of the most decorated bikes on the planet. But the Speedmax CFR Track is far from a mere rebadged triathlon bike – every inch has been meticulously sculpted and perfected for the velodrome.

"With the Canyon Speedmax CFR Track, we knew we had an opportunity to create something truly exceptional," said Daniel Heyder, Team Manager Product Management Road at Canyon. "Proven at the highest echelons of triathlon, the Speedmax served as the perfect foundation, but we went back to the drawing board and collaborated extensively with our aerodynamics partners, Swiss Side, to ensure every aspect of this bike was sculpted for supreme aero efficiency at the exceptionally high speeds and unique conditions of the velodrome."

The result is a masterpiece of engineering and aerodynamics. Every tube profile and every junction of the Speedmax CFR Track has been fine-tuned to slice through the air with unparalleled efficiency, giving track cyclists the ultimate advantage in their pursuit of speed and victory.



Pro-driven development

In a discipline like track cycling, where bike design has widely matured to a level bordering on perfection, there comes a time when striving for the next level of excellence demands a complete re-imagining of the rules.

So where traditional wisdom dictates that the design process starts with the engineering team, with the Speedmax CFR Track, pro riders drove development from day one. The process started at the sport's pinnacle – 8-time World Championship gold medallist Chloe Dygert – whose input shaped the initial design. Prototypes were then tested and evaluated by the Danish national track cycling team, whose long months of feedback directly fed back into the bike's meticulous evolution.

"The velodrome demands perfection, and our collaboration with professional track cyclists was crucial to achieving that. And with the Speedmax CFR Track, we started directly with the best around. We asked them: what kind of bike do you need to win races? And their expertise and feedback helped shape the Speedmax CFR Track into the exceptional machine it is today," explains Lukas Schuchnigg, Development Lead, Speedmax CFR Track.

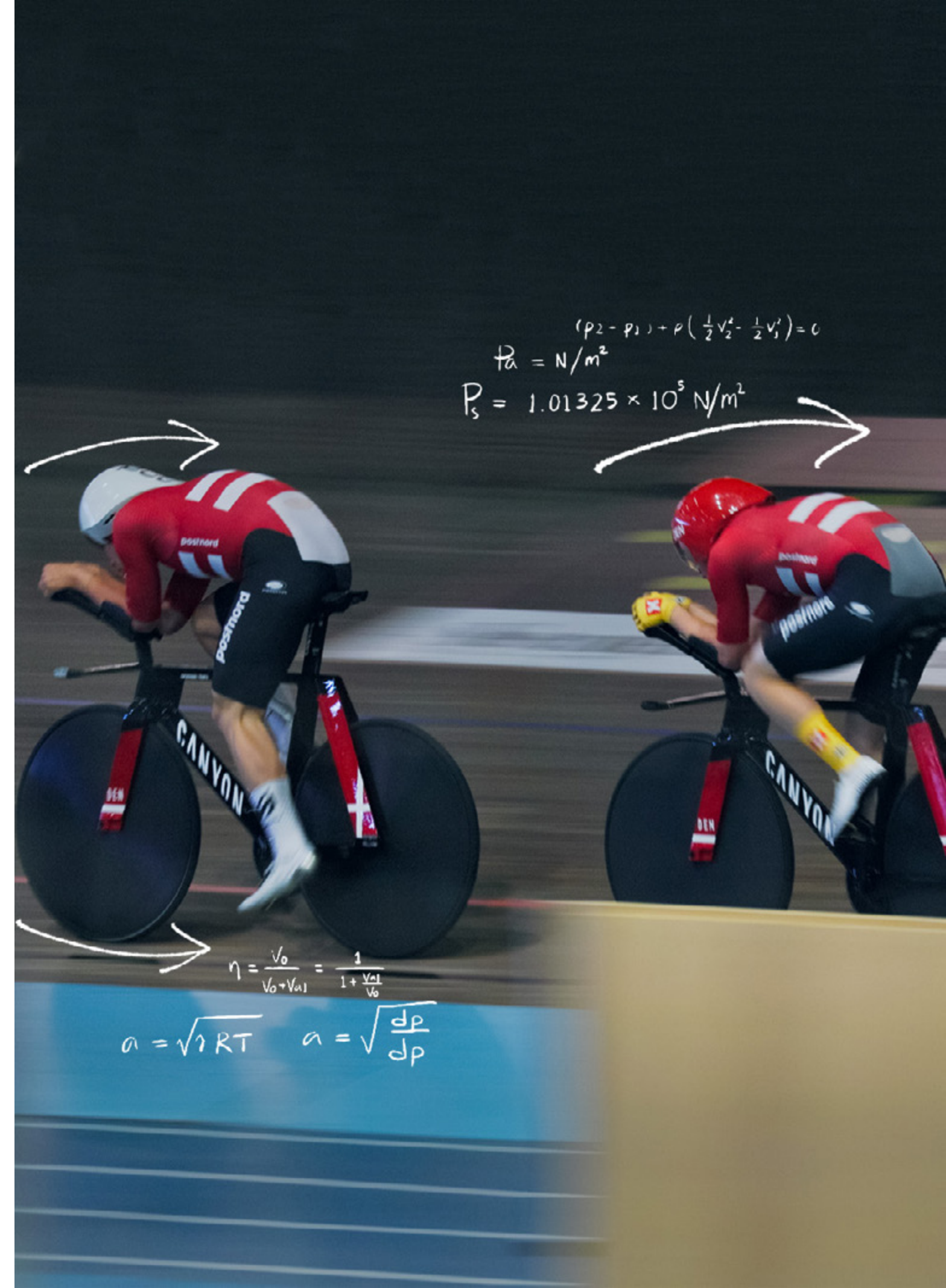

The finest components

In the relentless pursuit of speed, the Canyon Speedmax CFR Track also comes equipped with the best-of-the-best components available today. A premium SRM Origin Track power meter features spider-integrated sensors for accurate wattage readings with no recalibration required. The Kappstein Pro Line Elite chainring's sensational stiffness maximises power transfer to save milliseconds on the track. Continental Grand Prix 5000 TT TR tyres combine minimal rolling resistance with maximum lightness and exceptional grip. Completing the package is Canyon's own fully adjustable carbon Pro Extension cockpit system, which combines incredible aerodynamics, comfort, and control into a world-class package.



SPEEDMAX TRACK



SHORT DOCUMENTARY

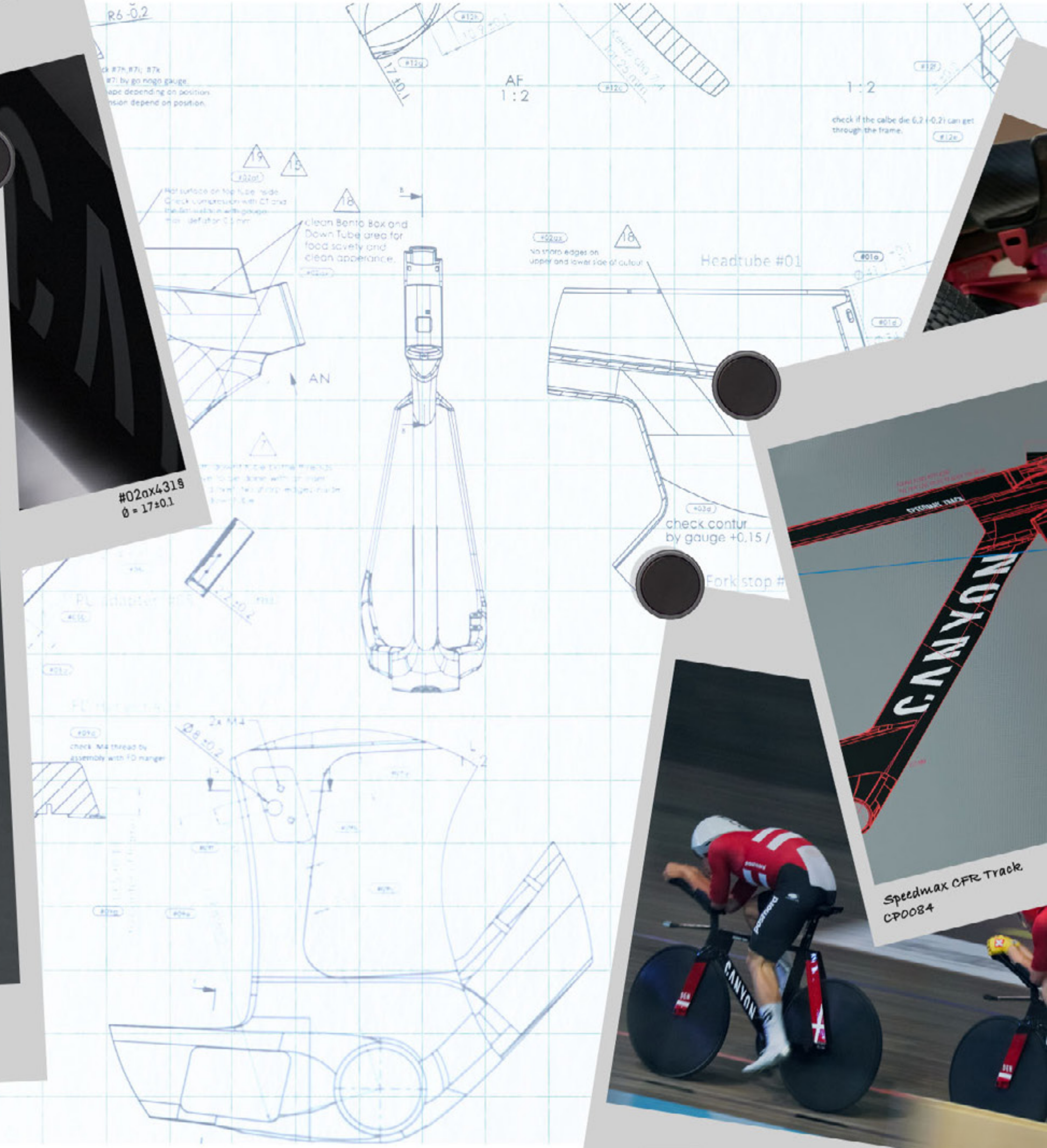
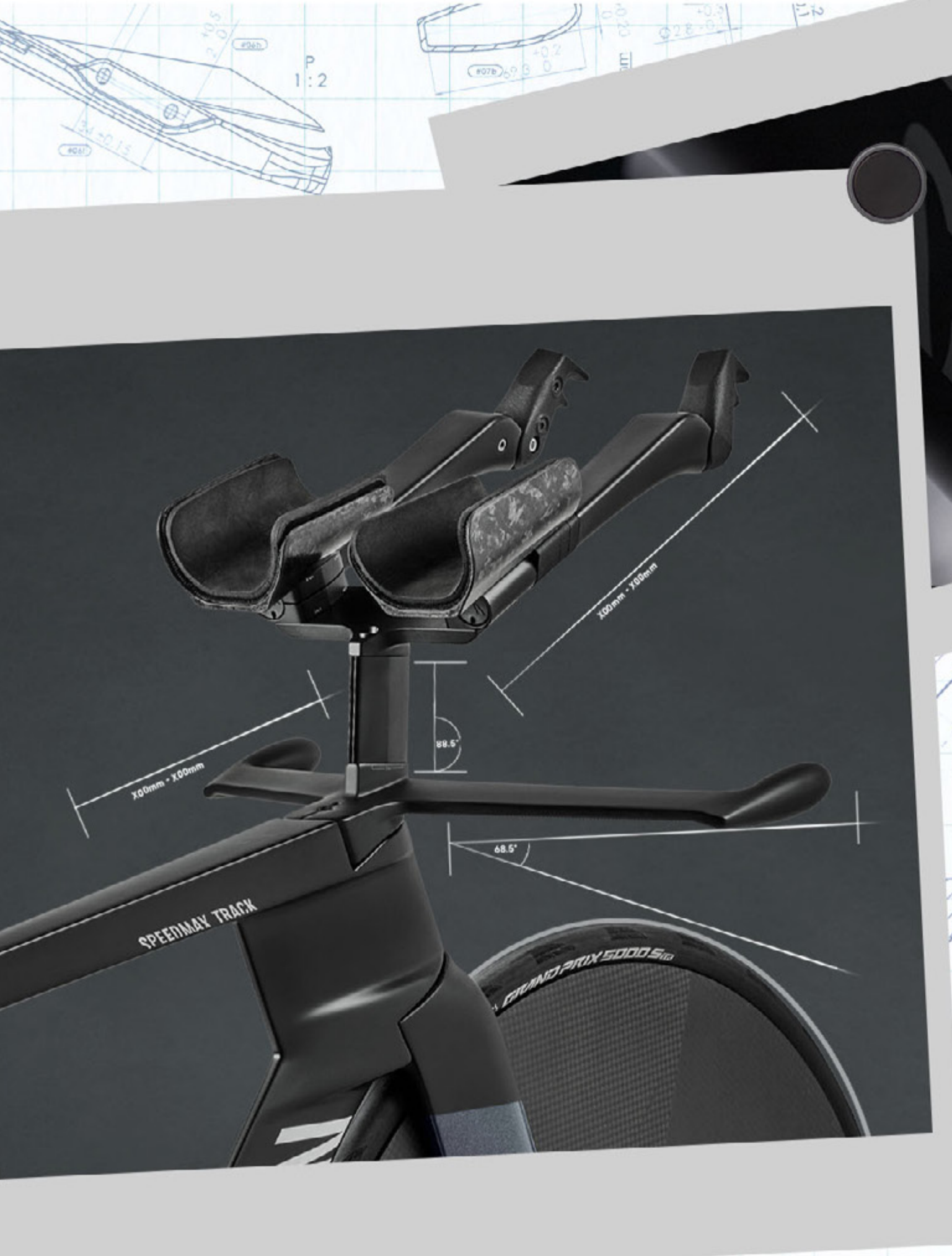

#02ax431s
 Ø = 17±0.1



Speedmax CFR Track
 CP0084

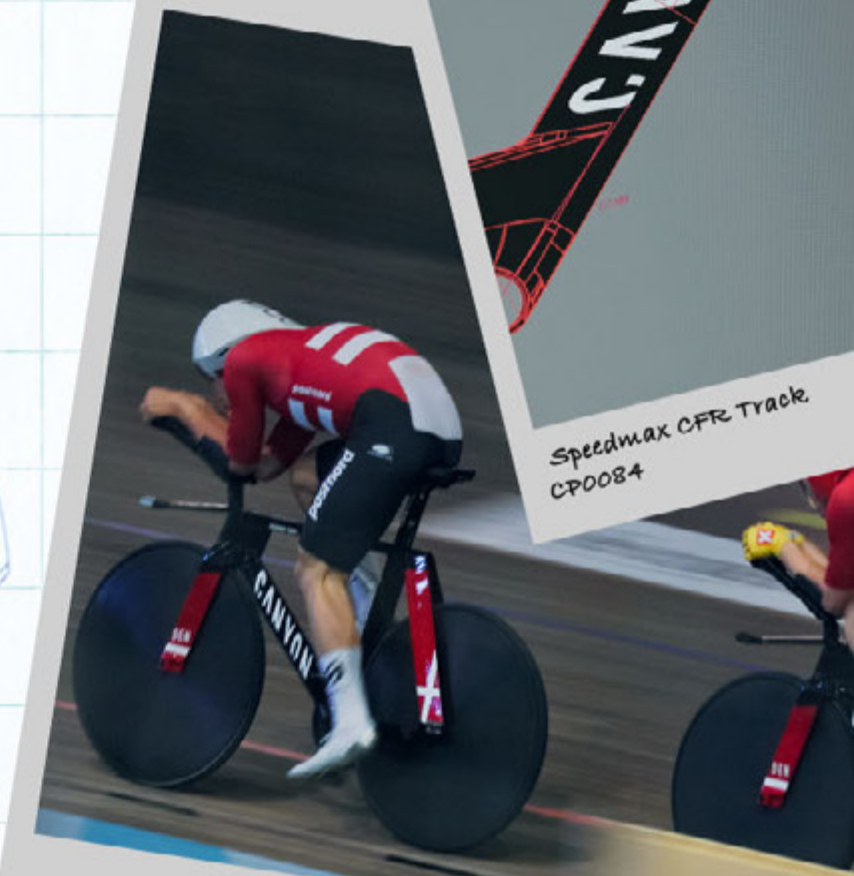

Introducing the Canyon Disc Wheel

Made for the track – experience pro-level aerodynamics, stiffness, and handling precision with the first ever wheel developed by Canyon. Enjoy a stable, planted ride thanks to huge levels of lateral stiffness to deal with the incredible lateral forces generated on banked velodromes. All optimised for minimal rolling resistance and maximum speed with 25mm wide clincher tyres vantage in their pursuit of speed and victory.



SRM Origin Track Powermeter

Power meters don't come better than this. This SRM unit measures your wattage using spider-integrated sensors, accurate to a super precise +/- 1%, all with no recalibration required. It comes with an app and is compatible with ANT+ and Bluetooth LE protocols.



Kappstein Pro Line Elite

Superlight, super-stiff chainring designed for the demands of professional track racing. The unique round-tooth design reduces power loss and wear to a minimum. These chainrings are only manufactured from the finest 7075/T6 aluminium, specially coated for the very highest levels of performance.

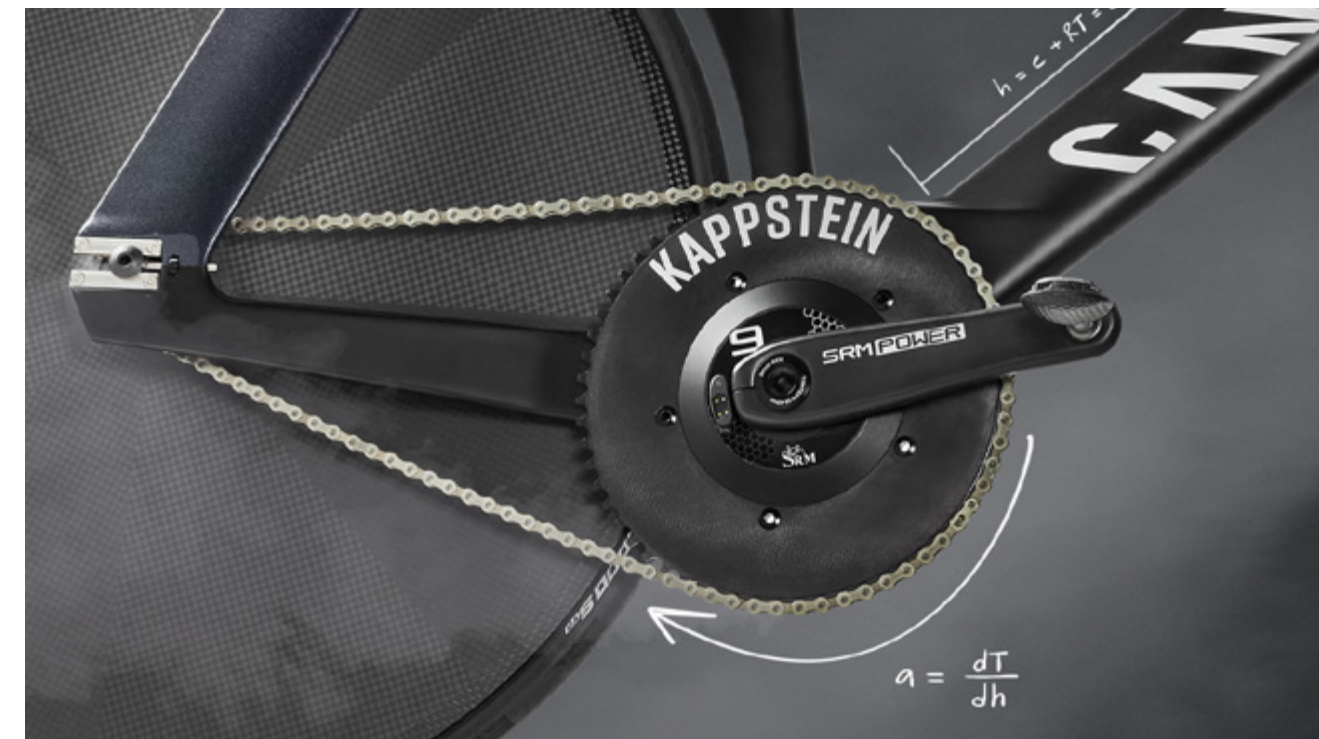

Continental Grand Prix 5000 TT TR

When every second counts, look no further than these tyres. The BlackChili rubber compound combines maximum speed with incredible lightness. Plus enjoy incredible grip in the corners, thanks to an advanced lasered micro profile structure. Tubeless ready and hookless compatible.

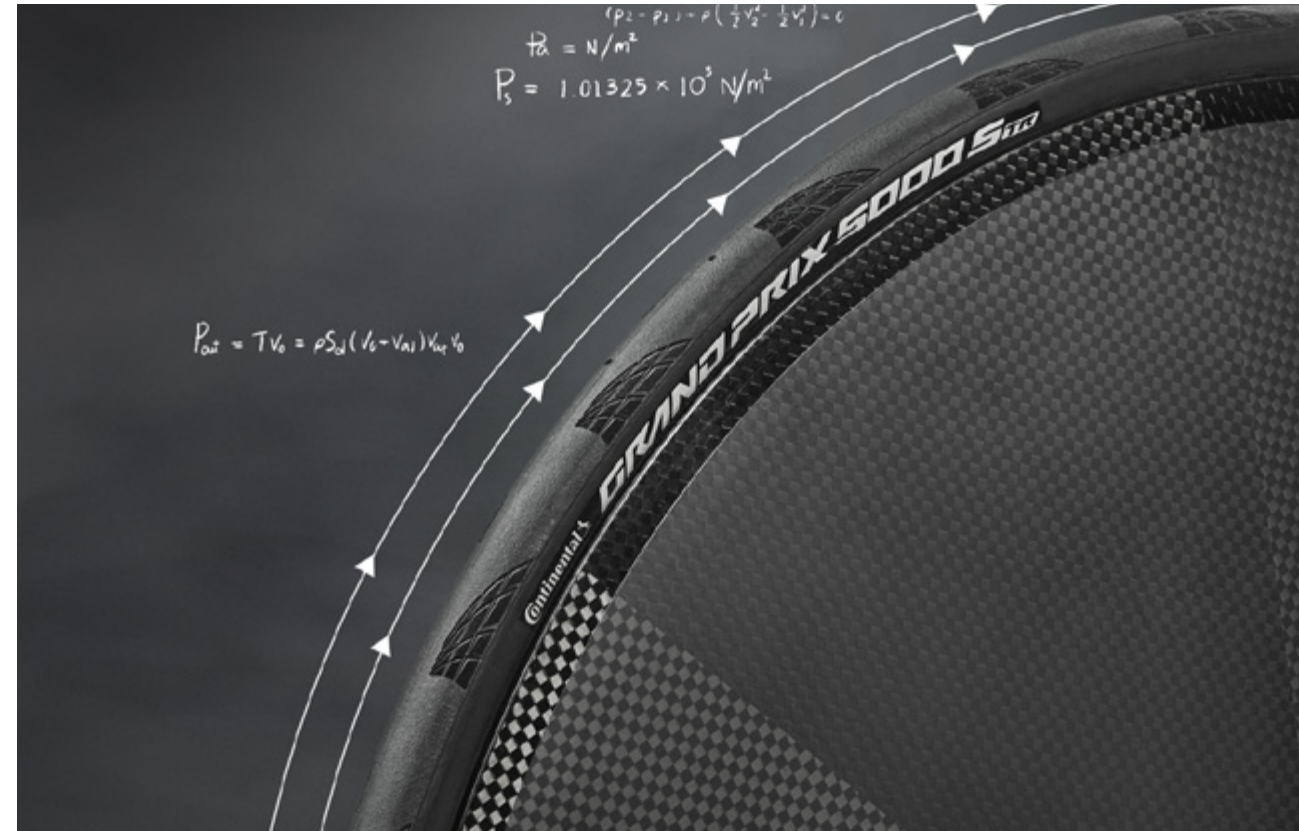

Fully adjustable carbon Pro Extension System

We specially optimised this advanced cockpit for track cycling – for the ultimate in aerodynamics and comfort, it features ergonomic adjustable carbon extensions and interchangeable, adjustable grips. And for maximum stability and optimal control, the carbon armrests have an enlarged contact area too.

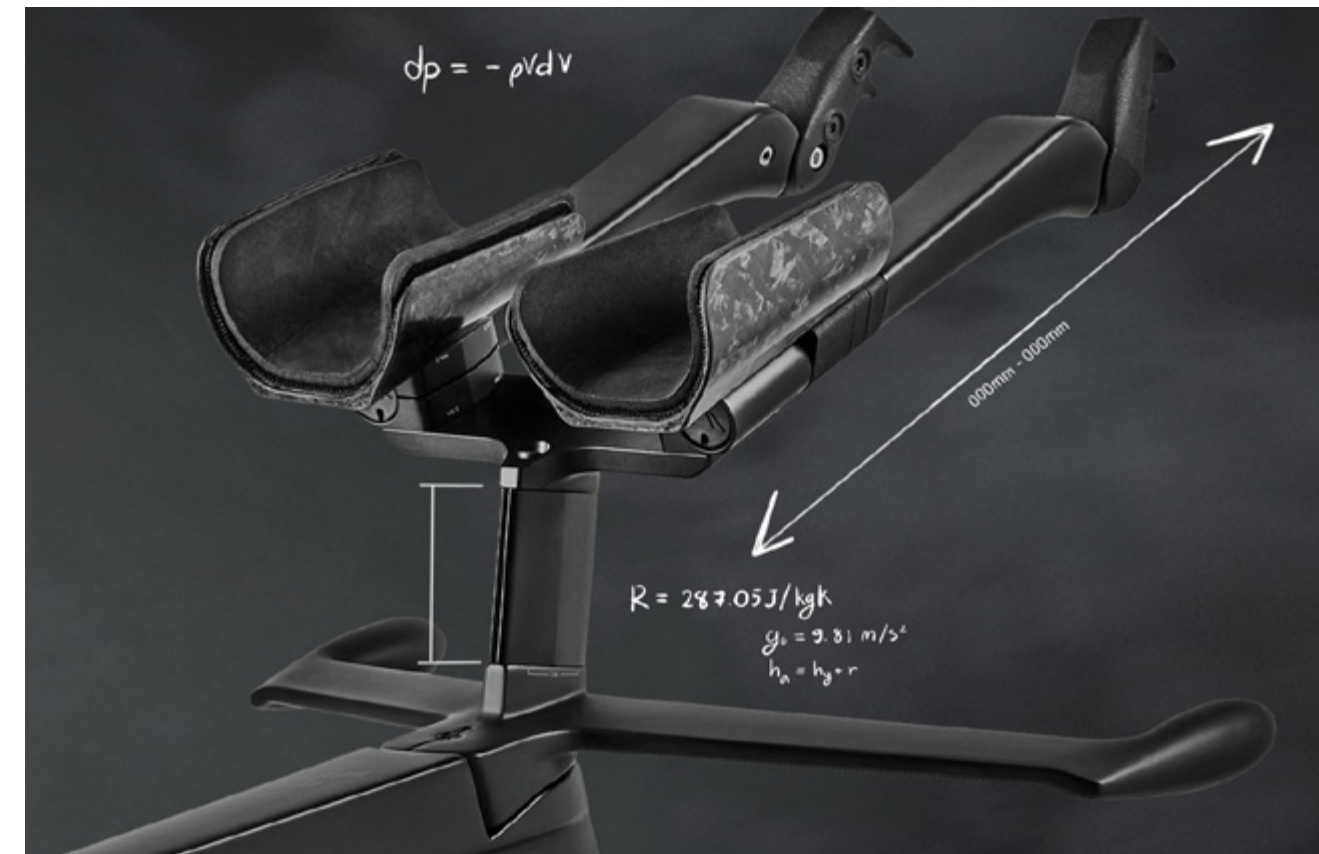

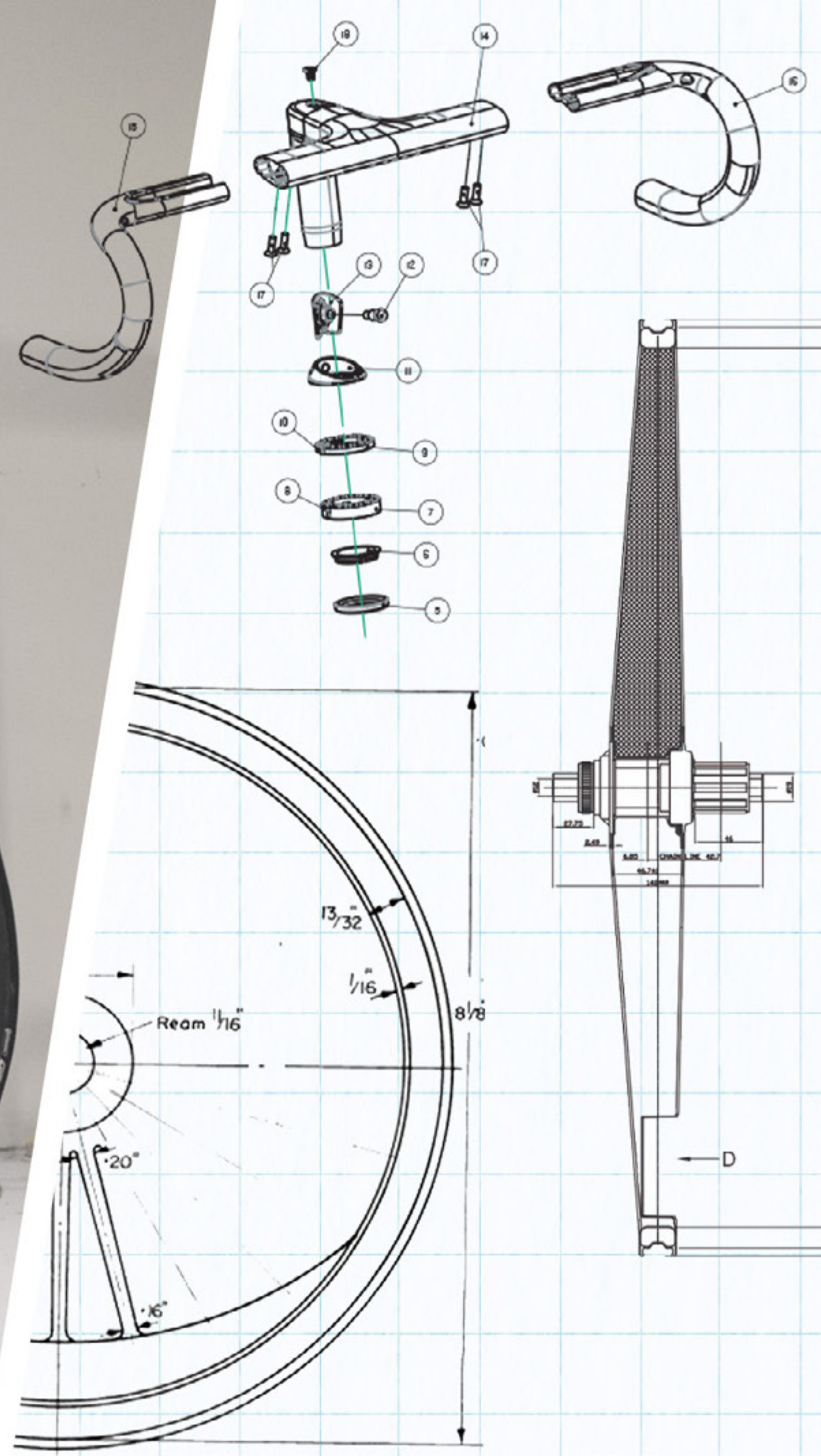

All disciplines covered

From individual pursuits to mass-start scratch races: with its replaceable fork, cockpit, and optional aftermarket spoked front wheel, the Speedmax CFR Track is built to win any race.

Bunch handlebar kit

Developed by industry-leading engineers, the Speedmax CFR Track can now be ordered through our in-house consultants. For your personalised ordering experience, get in touch.



Aftermarket spoked front wheel

Mix it up at the front of the pack with our lightning-fast spoked front wheel, specially developed for mass-start events.





Available 3 August

The Speedmax CFR Track is Canyon's fastest-ever bike, boasting cutting-edge components and unrivalled adaptability for track cyclists seeking the pinnacle of performance. Available 3 August, exclusively at [canyon.com](https://www.canyon.com).

© CANYON 2023. ALL TEXT, IMAGES AND OTHER PUBLISHED INFORMATION ARE COPYRIGHT OF CANYON BICYCLES GMBH OR HAVE BEEN GIVEN PERMISSION BY THE RIGHT HOLDER IF STATED OTHERWISE. ALL INDICATIONS WITHOUT ENGAGEMENT. ERRORS AND OMISSIONS EXCEPTED.

IMPRINT

CANYON BICYCLES GMBH
KARL-TESCHE-STRASSE 12
56073 KOBLENZ
GERMANY

CANYON.COM

01.08.2023